

9KW Water parking heater

Technical description, installation, operation and maintenance instructions.

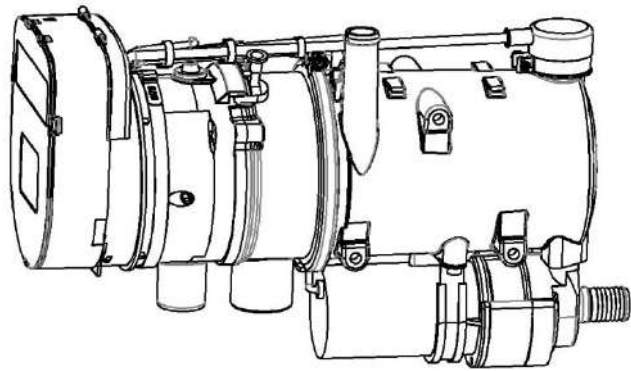

Product type	Order No.
Diesel 9KW12V	4W1009 12C13
Diesel 9KW24V	4W1009 24C13
Gasoline 7.6KW 12V	4W1009 12Q13

Water heater for operating independently of the engine.

Preface

Thank you for choosing 9KW water parking heater

This instruction book describes the structures, working principles, installation and operation of the parking heater. For correct use of the heater, please read this instruction book carefully before installation and use. The instruction book shall be saved in a convenient place for later reference.

Attention:

- This instruction book is subject to revision without notice, but the instruction book is in conformity to the purchased product.
- Our effort is to explain all questions the users may have through this instruction book. If you have any doubts or find anything incorrect in this instruction book, please contact our company directly.
- At first unpacking, please check the heater and its accessories against the packing list. Please contact the dealer immediately if any problem is found.
- If any trouble arises during application, please contact the Department of Marketing of our company or other customer service stations authorized by this company. We shall do our best to provide service to you.

Note:

Comply with the operational manual for installation and use
to ensure that the heaters can work for a long time.







1 Introduction

The heater is a multi-function of environmental protective and highly intelligent remote control parking heater (hereinafter referred to as the heater). The main heater is a small fuel furnace controlled by a single-chip microprocessor. Its medium circulation system is connected with the cooling system of automobile engine. In such a way, the cooling liquid for engine can be heated by the heater while the engine is not working. The heater not only can heats compartment and rest room to a proper temperature but also preheats medium and large engines, so as to avoid cold starting and increase service life of engines. Heaters can offer comfortable temperature during the set period. This allows for maximum relaxation and recuperation of the driver, obviously increased the safety of driver and cargo. Heaters can avoid idling and cutting the cost, carbon dioxide and fuel consumption can be reduced. Make a great contribution to environment protection.

1.1 Product Characteristics

- Delivery terms can be customized.
- Both as original and installation equipment.
- Work at any time even in the low ambient temperature.
- Eliminate idling and reduce fuel consumption.
- Compact structure, easy installation and maintenances. When you buy a new car, the heater can be dismantled and installed on the new car.

1.2 Scope

■ Truck	■ Bus	■ Off-highway
		
■ Rail	■ Special vehicle	■ Defenses
		

2 Technical Specifications

Heater dimensions shown as Fig.1

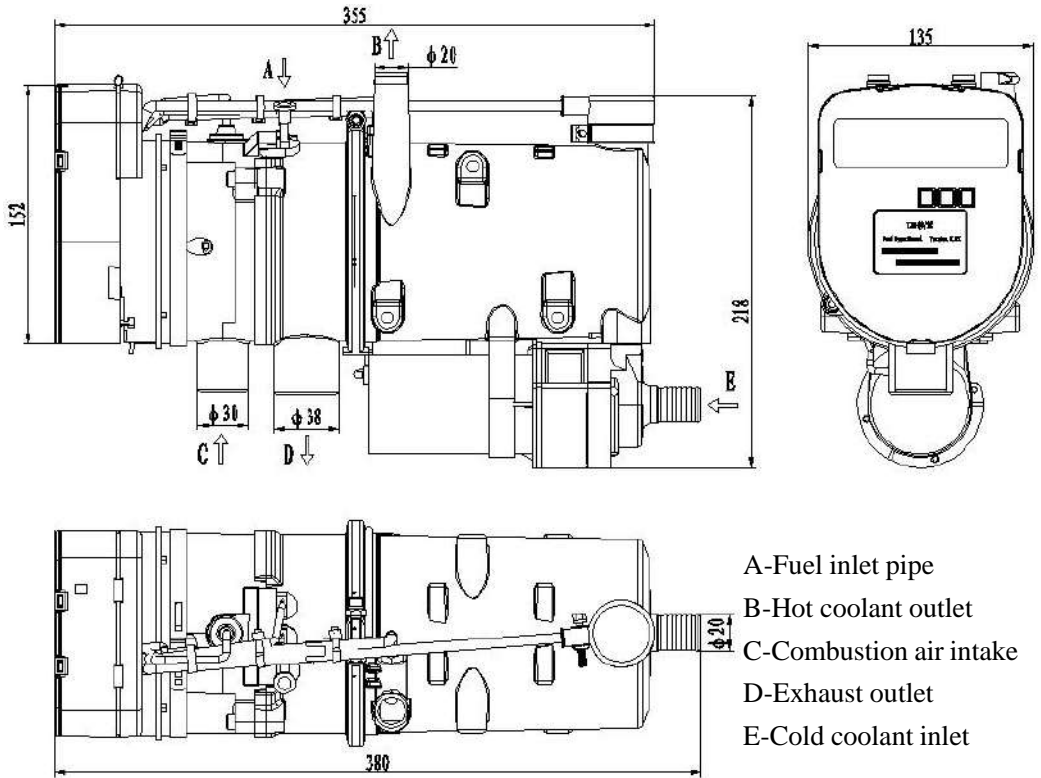

Fig 1

Technical specification for heaters

Heating Medium		Coolant	
Thermal power	Max		9.1KW
	Regulating range	2.0~7.6kW	1.8~7.6kW
Fuel		Gasoline	Diesel
Fuel consumption	Max		1.1 l/h
	Regulating range	0.25~1.0 l/h	0.19~0.9 l/h
Power supply (Common battery for the engine)		DC12V	DC12/24V
Power consumption	Max		90W
	Regulating range	37~83W	
Working pressure		2.0bar	
temperature range	Control unit	Operation	-40~75℃
		Storage	-40~85℃
	Fuel pump	Operation	-40~20℃
		Storage	-40~85℃
Water pump circulation (0.15bar)		1650 l/h	
Working height above sea level		≤5000m	
Net Weight (Only heater)		4.8kg	
Mobile phone control (Optional)		No limitation	
Temperature of coolant when warm blower is started		45℃	

3 Structure and working principles

The heater is installed by series connection with engine coolant circulation system. First remote control unit or LCD switch give electronic control unit a start signal, then the fuel from fuel tank is jetted on the metal felt of combustion chamber by fuel pump, glow plug can gasify and ignite the small fuel drops when its temperature reaches about 1000 ℃ ,engine is heated by the coolant which is heated by the flame in combustion chamber. Warm air blower is starting and blowing the warm air into compartment when the coolant gets the temperature of warm air blower starting.

3.1 Coolant circulation system (Fig.2)

The cooling liquid of engine flows through water inlet pipe 9, water pump 11, the furnace cavity between the furnace inner casing 8 and outer casing 6, and water outlet pipe 1, forming a complete loop for the cooling liquid circulation system. The circulation is forced by water pump 11. In this way, the cooling liquid of engine can be heated circularly in the furnace and the temperature of engine, water tank, heat exchanger and compartment can rise gradually.

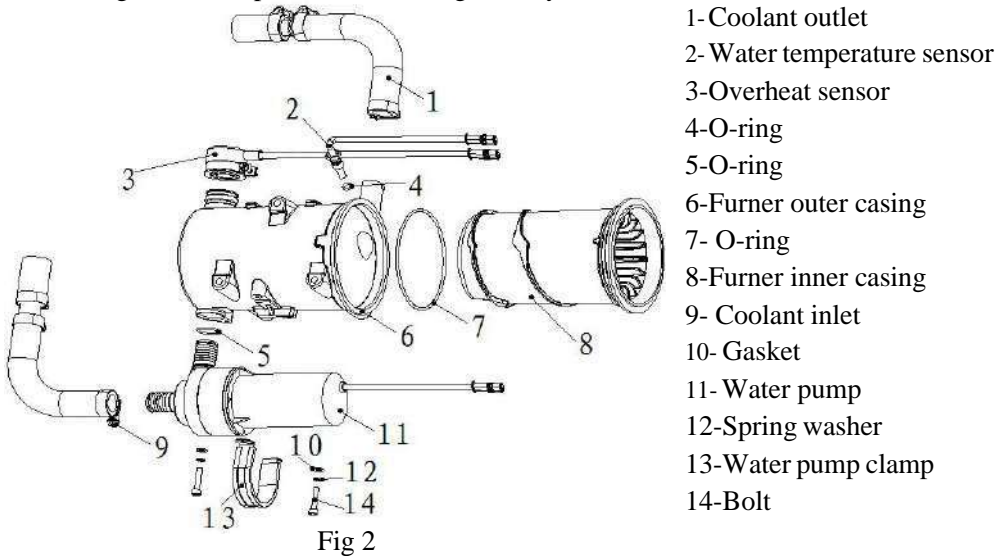

Overheat sensor 3 is used to measure the temperature of the furnace inner casing. The heater will be shut down automatically in case of overheating due to inadequate water in furnace cavity or other problems.

Water temperature sensor 2 is used to measure the temperature of coolant and determine whether the warm blower of the heat-exchanger in the car needs to be started and also determine the working conditions of the heater.

3.2 Furnace

The main body of furnace consists of furnace outer casing 6(Fig.2), furnace inner casing 8(Fig.2) and combustion chamber (Fig.3), etc.

Heating process: Fuel pump draws fuel from fuel tank by fuel inlet pipe 2(Fig.3) and send it to combustion chamber to mix with combustion supporting air. The mixture is to be ignited by glow plug 9 (Fig.3). The fresh air from air intake pipe is blown into combustion chamber by combustion supporting fan for sufficient burning. The exhaust gas, after flowing through the muffler is to be released to the air by the exhaust pipe.

Flame sensor 7(Fig.3) is used to measure the temperature of the combustion chamber so as to judge if the combustion chamber has been ignited and keeps burning after the ignition.

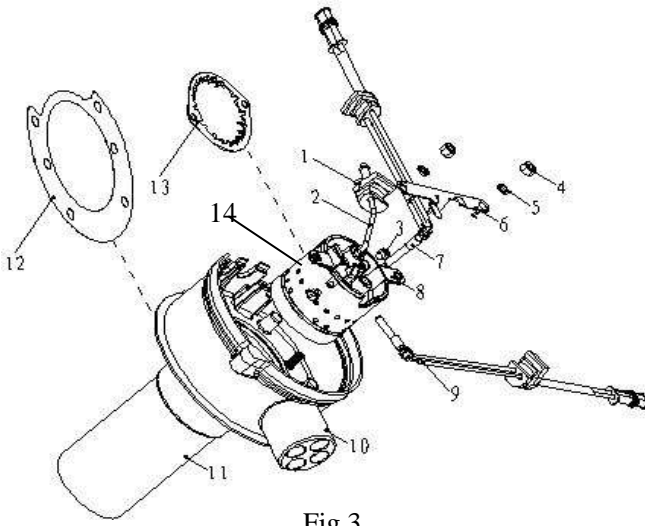

Fig.3

- 1-Seal plug of fuel inlet pipe
- 2-Fuel inlet pipe
- 3-Screw 4-Nut
- 5-Spring washer
- 6-Wire bracket
- 7-Flame sensor
- 8-Combustion chamber bracket
- 9-Glow plug
- 10-Burner outer casing
- 11-Combustion pipe
- 12-Gasket
- 13-Swirl ring
- 14-Combustion chamber

3.3 Air inlet chamber (Fig.4)

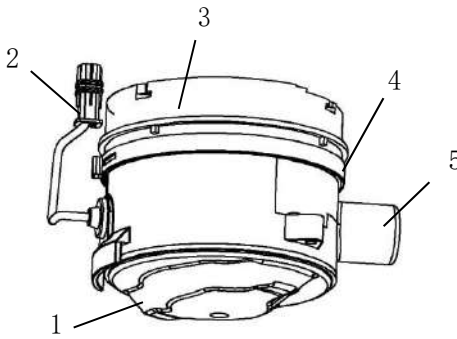

Fig. 4

- 1-Air inlet chamber cover
- 2-Fan motor plug
- 3-Combustion air fan cover
- 4-Clamp
- 5- Combustion air intake

3.4 Control unit

3.4.1 Structure (Fig.5)

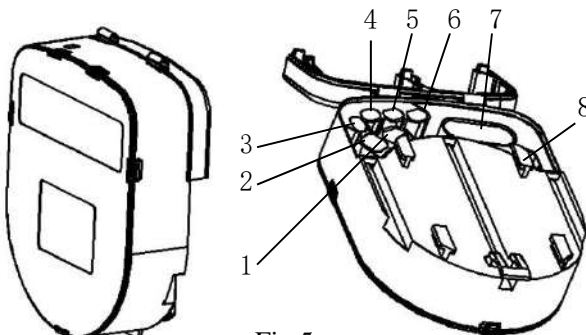

Fig 5

- 1- Electric plug socket
- 2- Fan motor socket
- 3- Water temperature sensor socket
- 4- Flame sensor socket
- 5-Water pump socket
- 6- Overheat sensor socket
- 7- Wire harness socket
- 8- Fuel pump socket

3.4.2 Function

3.4.2.1 Monitor the voltage of power supply and to decide if it can meet the requirements of work.

3.4.2.2 Check if there is any open-circuit or short-circuit trouble with the combustion supporting fan, water pump, glow plug, flame sensor, overheating sensor, water temperature sensor, etc.

3.4.2.3 Carry out control on glow plug's time of power-on and duration of power-on.

3.4.2.4 Carry out control on speed of rotation of the combustion supporting fan in heater's different phases of working.

3.4.2.5 Adjust fuel feeding rate of fuel pump automatically according to heater's different phases of working.

3.4.2.6 Determine (or adjust) working conditions of heater according to data collected from flame sensor, overheating sensor and water temperature sensor.

3.4.2.7 Carry out control on working conditions of the water pump.

3.4.2.8 Switch off the equipment automatically if some troubles arise during working. The equipment can be switched on again if necessary.

3.4.2.9 Troubleshooting can be analyzed and eliminated by LCD switch.

3.5 On/Off Operation

Switching on or off of the heater can be completed by a LCD switch or remote control unit or GSM control unit. Please refer to Chapter 5 Methods of Operation for details.

3.6 Power Supply

The power supply to the heater is the storage battery in the automobile. The power supply is with an independent security control device.

Attention: Heater using time can't longer than driving time every day, or car battery will be lack of the electricity(Charging is necessary in time).If battery for more than 2 years which is often lack of the electricity, you need change a new battery in order to the heater can work normally.

3.7 Fuel Supply

The fuel for the heater can be from the fuel tank for driven automobile, besides 5 L fuel tank can also as the option.

4 Installations

Only special-purpose parts as shown in Fig. 6 can be used for installation of the heater. The positions and ways of fixing of various parts may vary from one automobile model to another, but the general principles shall be in conformity to the requirements of this chapter.

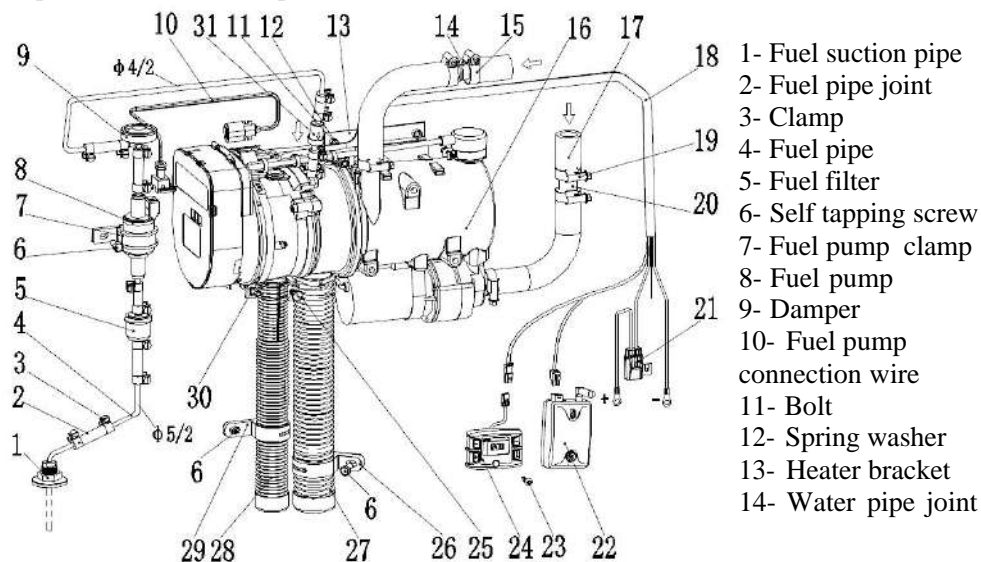

Fig. 6

4.1 Installation Site and Use of Heater Requirements

4.1.1 It is not allowed to use the heater in locations with inflammable or explosive substances such as flammable gas or flammable dust.

4.1.2 It is not allowed to use the heater in closed space (such as garage) to avoid danger of poisoning by exhaust from burning.

4.1.3 It is not proper to install and use the heater in house.

4.1.4 It is not allowed to use the heater in passenger compartment, cab or any other space where people are staying.

4.1.5 If the heater is installed in special-purpose vehicles (such as vehicles for dangerous goods), special rules must be followed.

4.1.6 Pay attention not to place fuel tank, gasoline tank, compression tank, fire extinguisher, clothes, paper, etc. near the heater.

4.2 Installation of the Heater

4.2.1 The heater is mounted on automobile with a bracket. The bracket and heater, bracket and car should be installed in order according to actual situation.

4.2.2 The main equipment shall be installed in the engine chamber as deeply as possible, so as to facilitate heat conduction and enable the water pump to evacuate air automatically. The installation position should also consider the water pipe which supplied by manufacturer as short as possible. An additional water pipe should not be used; otherwise it may affect the normal working of warm air.

4.2.3 Choice of position for installation of the main equipment shall keep the air from the water pipe discharge normally. It is allowed to incline to suit different arrangements for installation, but deviation from the “normal installation position” shall not exceed 90° , as shown in Fig. 7.

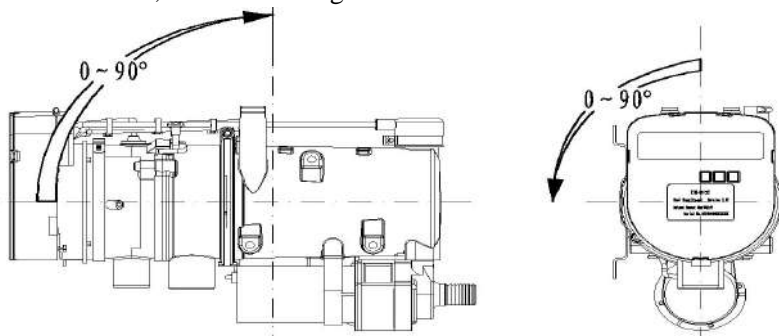

Fig. 7

4.3 Installation of Cooling Liquid Circulation System

4.3.1 At installation, the existing cooling liquid in automobile must be evacuated and use clean water to rinse the system. Then, new liquid can be filled in.

4.3.2 Connect the heater master with the engine coolant circulation system as shown in Figure 8, 9 or 10.

Connected in Figure 8 or 10, the heater and the heat exchanger of warm blower series, engine and passenger compartment heating at the same time.

Connected in Figure 9, the heater is connected in parallel with the heat exchanger of warm blower, engine preheating fast.

Connected in Figure 9 or 10, when the engine is working alone, the hot water no longer flows through the heater (to avoid heat loss), feel warmer.

Connected in Figure 10, the arrow direction of Non-return valve must be consistent with the direction of the engine!

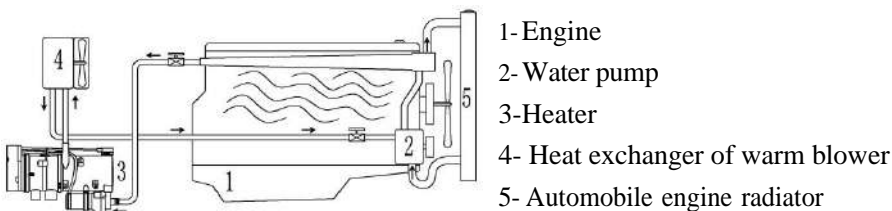

Fig. 8

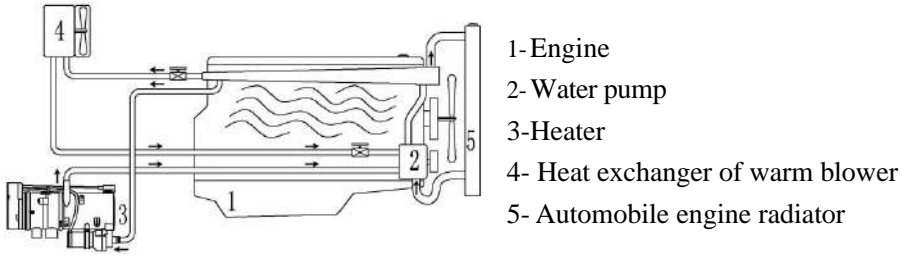

Fig. 9

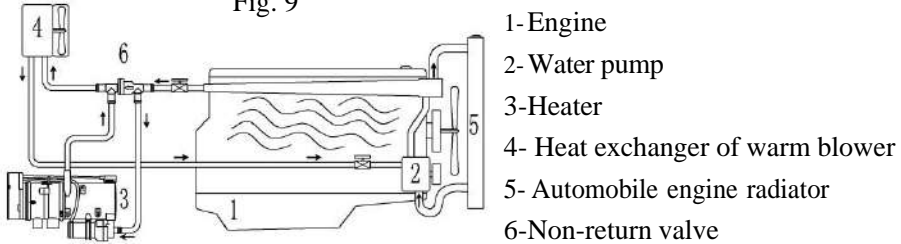

Fig. 10

4.3.3 Cooling liquid should be filled in system. If you want to use the original cooling liquid, you have to clean it with a filter.

Attention: The coolant used must accord with relative winter use rules of car manufacturer. The coolant not only can anti-freeze but also have anti-rust function. So water can never be added and only add coolant.

4.3.4 If a used heater is to be installed in other vehicles, please use clean water to rinse the inner cavity of the cooling liquid circulation system of the heater.

4.3.5 Start the car engine in order to circle the coolant after the heater is installed, set the air conditioner in warm air blower position. The bubble in the coolant circulation system can be eliminated when the warm air can blow normally.

4.4 Installation of Air Intake and Exhaust System

The air inlet pipe and exhaust pipe must be the special-purpose parts, and are not supposed to cut short. The middle sections of the pipes shall be fixed with clamps (special-purpose parts, two of each) in proper locations.

4.4.1 The function of the air inlet pipe is to draw combustion supporting air into the main equipment for the furnace. It is required that the combustion supporting air must be drawn from the outside. It must be sufficient and fresh. Therefore, the vent of the air inlet pipe shall not be opposite to the air flow, and shall not be plugged by dust, rain or snow. The protective hood at the vent shall not be damaged.

4.4.2 The special-purpose exhaust pipe shall be cut off in proper position to form two sections: an exhaust pipe and an exhaust tail-pipe. The muffler shall be positioned in the middle and fixed with the muffler holder.

Attention: These parts are at high temperature when the heater is working. They shall be arranged far from the plastic parts and wires of the vehicle to avoid damage.

4.4.3 The exhaust (tail-) pipe shall not extrude out of the automobile contour. Its outlet position shall prevent intake of the exhaust by the air inlet pipe or convection fan (or far from the air inlet pipe and the air intake vent of the convector fan). Its outlet shall not be opposite to the air flow, and shall not be plugged by dust, snow or rain. The protective hood at the outlet shall not be damaged.

A small hole ($\varphi 2 \sim 5$) shall be drilled at the low end of the exhaust pipe for condensate to drain.

4.5 Installation of Fuel Supply System

The fuel supply system for the heater is as shown in Fig. 12.

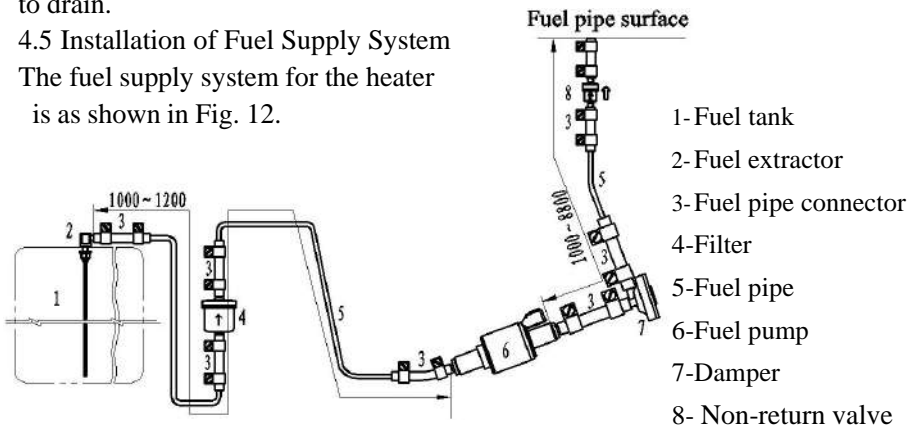

Fig. 12

4.5.1 The fuel pump shall be fixed in automobile with a fuel pump clamp with protective rubber cover. The outlet of the fuel pump shall tilt upwards. The tilt angle can be selected from the range of $15^\circ \sim 35^\circ$ (as shown in Fig. 14). When conditions permit, the fuel pipe between the fuel pump and the heater shall go up gradually.

The Non-return valve must be directly connected to the heater oil inlet pipe for installation!

Fill the line with fuel before installing the Non-return valve!

The Non-return valve has the function of preventing fuel evaporation.

4.5.2 The hole on the fuel tank cover is $\varphi 25 \pm 0.2$ for installation of the fuel extractor (only for metal fuel tank). The hole shall be made smooth without any burrs on the verge. An O-ring shall be placed beneath the fuel extractor seat. The low port of the fuel extractor shall be about $30 \sim 40$ mm from the bottom of the fuel tank. If it is too low, it becomes liable to suck the precipitating impurities from the bottom of the fuel tank and send into the fuel pipe.

4.5.3 Fuel pump and fuel pipes shall keep a distance from any heat source. They should not be installed close to the muffler or exhaust pipe, or fuel pipes shall be protected with adiabatic pipe.

4.5.4 The fuel pipe shall be fixed in place with ties in proper locations. The distance between two ties shall not be longer than 50 cm.

4.5.5 Connect fuel pipe, fuel pump, fuel inlet pie of the heater and fuel extractor with fuel pipe joint which made of rubber. The connecting place shall be tight without any gap (as shown in Fig. 13). Therefore, the ends of the fuel pipe shall be cut off evenly with a sharp blade to make smooth ends.

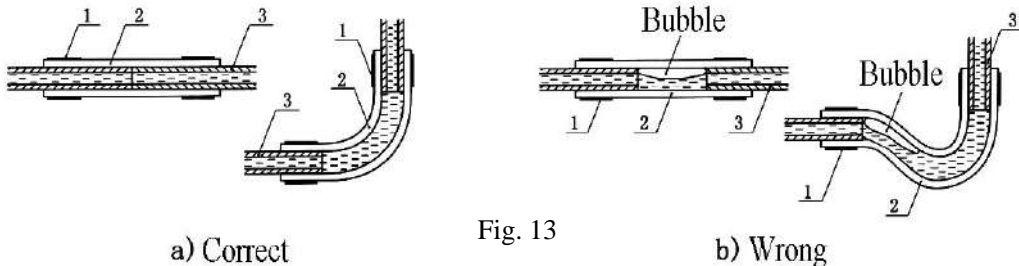

a) Correct

Fig. 13

b) Wrong

1-Fuel pipe clamp 2-Fuel pipe joint 3-Fuel pipe

Attention: connections are not allowed on the fuel pipe from the fuel pump to the heater.

4.5.6 Difference in elevation between the level of fuel and the fuel pump as well as the difference in elevation between the fuel pump and the fuel inlet of the heater can produce pressure (or suction) in the fuel pipeline (See Fig.13). So, these dimensions shall conform to the requirements as follows:

$a \leq 3\text{m}$ $b \leq 0.5\text{m}$ (Avoid of negative pressure may be produced in sealed fuel tank. In such case, $b \leq 0.15\text{m}$) $c \leq 2\text{m}$.

Note: please check the vent on the fuel tank when doing installation.

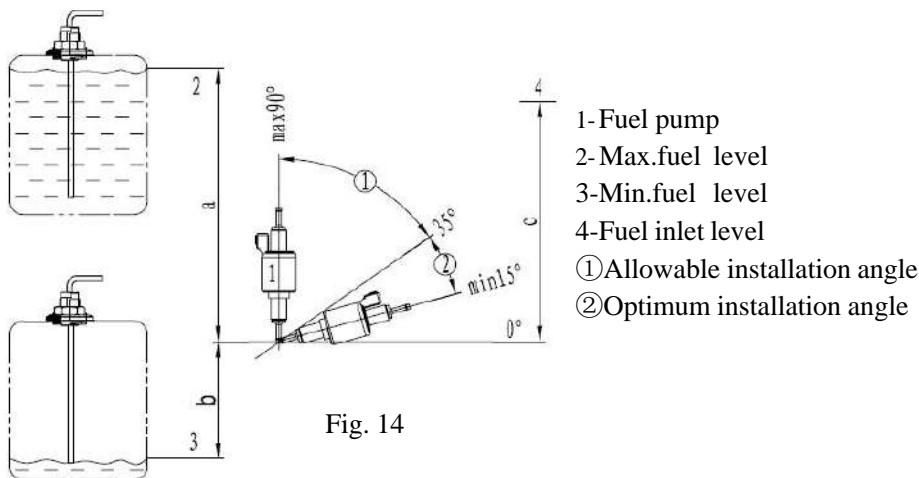

Fig. 14

4.5.7 Installation of fuel filter

Fuel filter should be installed before the fuel inlet of fuel pump, flow direction mark "A" should be correct when doing installation. The installation position of fuel filter should accord with requirement of Fig.15.

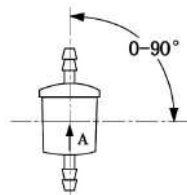

Fig.15

Fuel filter should be changed every year, fuel pipe joint and clamps should also be changed.

4.6 Installation of Electrical Parts

The wiring diagram for the heater is shown in Fig. 16.

4.6.1 The wire circuits outside the heater have been made into wire bundles. They can be laid according to the positions of various components and shall be fixed in some proper locations. The distance between two fixing points shall not exceed 30 cm. Attention: Any exposed wire bundle out of the automobile body or out of the wiring groove must be protected by adiabatic pipe.

4.6.2 The positive wire (2.5mm², red) of power supply of the heater shall be connected to the positive terminal of the battery of automobile. The negative (ground) wire (2.5 mm², brown) shall be connected to the negative terminal of the battery of automobile.

The length and cross-sectional area of the power line shall ensure that the allowable voltage drop is not greater than 0.5V and 1.0V when the voltage is 12V and 24V. It is recommended to configure the power cord according to the following table.

Plus cable + minus cable	cross section
<8m	2.5mm ²
8~12m	4mm ²
12~16m	6mm ²

4.6.3 All electrical components of the heater shall be connected to the wire bundles through connectors. You just need to plug into connectors and make connections according to their corresponding relations.

4.6.4 For those components whose connecting wires may need to go through small holes (such as LCD switch and remote control receiver), you need to pass the wires through the holes before the connection is made to the connector. For such reason, the terminals of these components are not plugged in the sockets before they leave the factory. Connector for the remote control receiver: Plug connection shall be made according to wire color and serial number of terminals on the sockets. Other terminals have to keep correct relations according to the wires circuit before installation.

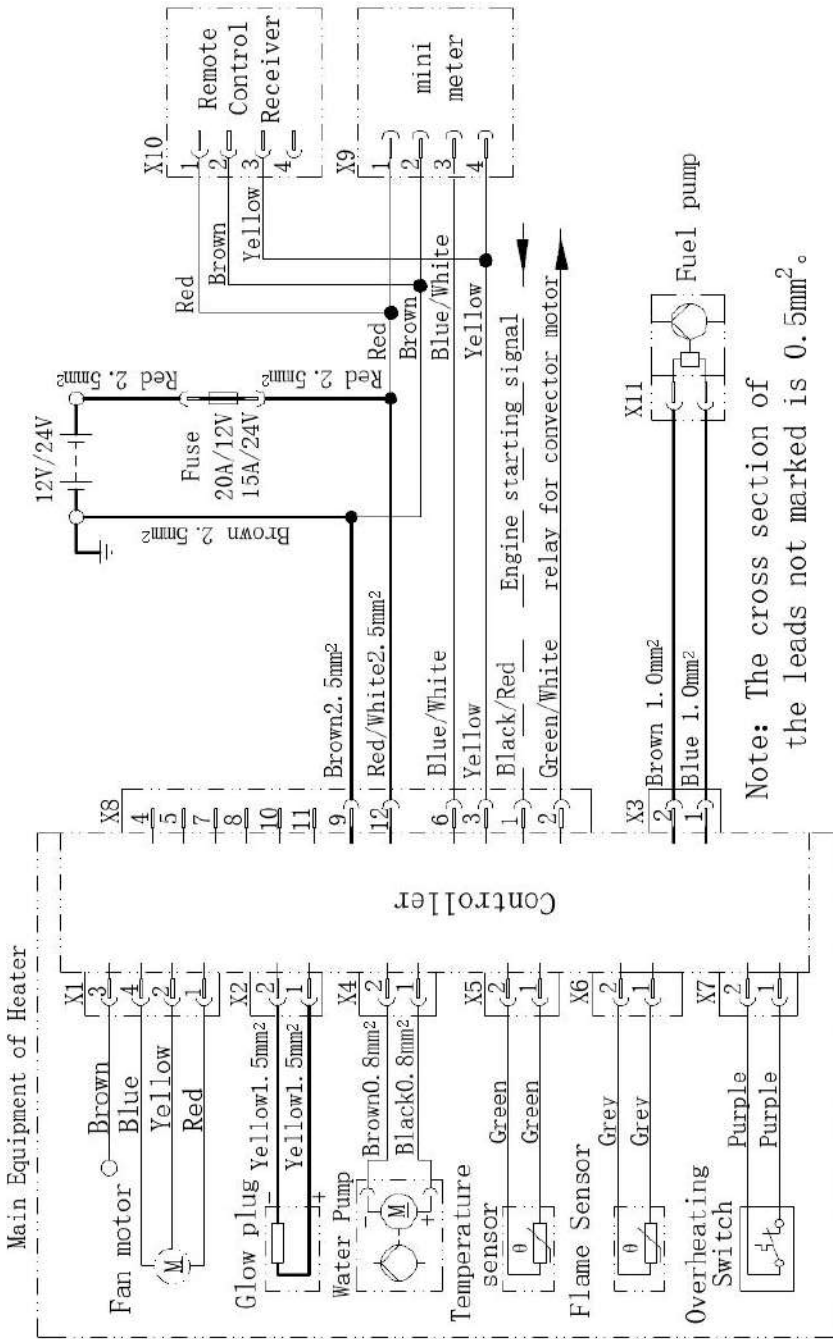

Fig. 16

5 Methods of Operation

5.1 The heater is operated by LCD switch or GSM remote controller. The LCD switch is installed in the cab. The GSM remote controller is installed inside the automobile.

5.2 The main modes of control on the heater include:

5.2.1 Manual power-on and manual power-off.

5.2.2 Manual power-on and automatic power-off when working time has come to a preset length.

5.2.3 Automatic power-on at preset time and automatic power-off when working time has come to a preset length.

5.3 Before turning off the engine, you should set the A/C as the warm air mode and keep I or II gear for the manual A/C, keep the A/C in “Open” position for automatic A/C. In such a way, it is convenient for heating the compartment next time.

5.4 LCD switch (Optional device, see Fig.17)

- Set heat starting time
- Set heat time
- Display fault information
- Eliminate fault code
- Digital display power level

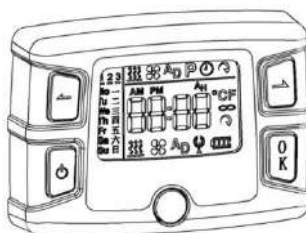

Fig.17

5.5 GSM remote controller (Fig.18)

GSM remote controller is an extended function device of parking heaters which can be started and stopped through calling or sending message to the number of SIM card in the GSM remote controller by phones or cellphones. Control ways include voice and short message. It can start and power off heater immediately.

Operation methods for LCD switch (optional) and GSM controller please see relevant instructions.



Fig.18

6 Treatments of Usual Troubles

If the heater is started by an operator but it does not work properly, the operator can try the following methods for a treatment.

6.1 Turn off the heater and start it again. But pay attention. Do not re-start more than twice.

6.2 Check if the fuse connection between the battery and the heater is correct.

6.3 If the temperature of cooling liquid is higher than 75 °C, the heater can only be started after the temperature is reduced through pump circulation.

6.4 In case of overheating please check the level of cooling liquid. If it is not sufficient, please fill up cooling liquid after its temperature lowers down then start the heater again.

If normal start is still impossible after above-mentioned examination, please contact our service station.

Fault code

Code	Fault
10	The voltage is too high
11	The voltage is too low
12	The temperature of software is too high
13	Second starting failure
14	The temperature of coolant or overheat sensor over high.
15	The heater is dead locked (overheat more than 10 times)
17	The temperature of the hardware is too high
20	Glow plug has a broken circuit
21	There is a short in circuit of the glow plug
30	The rotate speed of the fan is too low
31	The fan has a broken circuit
32	A short circuit of the fan
33	Fan speed is too low
38	There is a broken circuit of the blower
39	A short circuit of warm air blower
41	A broken circuit of the water pump
42	A short circuit of the water pump
47	A short circuit of the oil pump

Checking and eliminating fault code see instructions of LCD switch.

Code	Fault
48	There is a broken circuit of the oil pump
50	The heater is dead locked(The twice failure to start more than 10 times)
51	Flame sensor check over high temperature during the starting time
52	Combustion interrupt
60	There is a broken circuit of the temperature sensor
61	There is a short circuit of the temperature sensor
64	A broken circuit of the flame sensor
65	Flame sensor is short-circuited
71	A broken circuit of the overheating sensor
72	There is a short in circuit of the overheating sensor
99	Fault information invalid
B0	Communication fault
E1	Fault of controller
E2	Fault of controller

7 Precautions

7.1 Trial operation is necessary for the heater before it is put into normal use. If lasting dense smoke is observed or irregular combustion noise or fuel smell is sensed or overheating happens to electrical components, the heater must be turned off. Please take out the fuse, making the heater unable to operate.

The heater can only be put into use after it is tested by professional workers.

7.2 After power-on of the heater, the furnace does not ignite immediately. Ignition can only be started when the system self-testing is completed and the temperature of furnace cavity and temperature of cooling liquid are reduced to allowable level.

When the heater is turned off, the combustion supporting fan and water pump do not stop working immediately and they shall keep working for about one minute for purpose of heat dissipation

7.3 When you are going to add fuel, you have to turn off the heater in advance.

7.4 If any leakage is found in the fuel supply system, you should take the heater to an authorized customer service station for repair.

7.5 If the heater is left unused for long time, it shall be started once every month and work for ten seconds, to avoid blocking-up of pump or combustion supporting fan.

7.6 Attention: To avoid danger, when the cooling liquid becomes frozen, it is not allowed to start the heater.

7.7 If welding is carried out to the automobile, in order to protect the heater, you should disconnect the positive line of power supply from the battery and connect it to ground.

7.8 Only authorized customer service stations are allowed to provide repair and installation for the heater. It is prohibited to make repair by yourself or use non-manufacturer's parts or components so as to avoid danger.

7.9 The manufacturer shall not be held responsible for any damage to the heater if such is caused due to operations with violation against the regulations.

